

Floor washlight

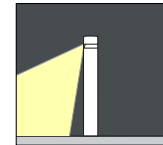
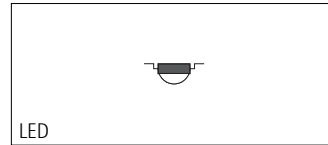
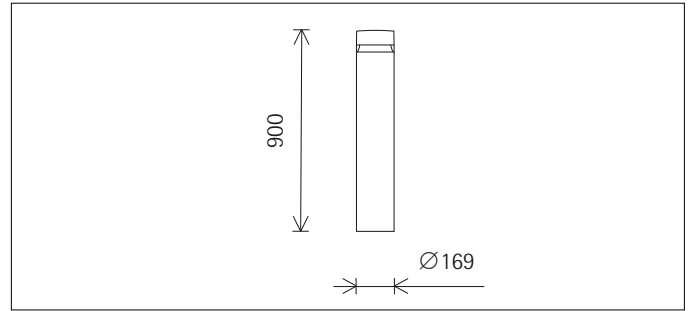

33924.000 Graphit m
LED 12W 1650lm 4000K neutral white
DALI
Version 1

Product description

For mounting on accessories.
Bollard: corrosion-resistant aluminium profile, No-Rinse surface treatment. Double powder-coated. Optimised surface for reduced accumulation of dirt.
Upper cover and base plate: corrosion-resistant cast aluminium, No-Rinse surface treatment. Double powder-coated. Base plate for mounting on ground socket, concrete anchor or mounting plate.
ERCO DALI control gear. 2 cable entries. Through-wiring possible. 5 terminals.
LED module: high-power LEDs on metal-core PCB.
180° light guidance ring made of optical polymer.
Anti-glare cone: corrosion-resistant cast aluminium, No-Rinse surface

treatment. double powder-coated and black lacquered.
Glare-free above the light aperture.
Mounting accessories to be ordered separately.
Protection mode IP65: dust-proof and water jet-proof.
Weight 9.72kg
Housing temperature 53°C
Maximum wind load area 0.15m²

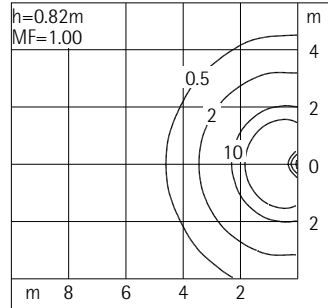

Technical data

Luminous flux of the luminaire	309lm
Connected load	15W
Luminaire efficacy	21lm/W
Colour deviation	2 SDCM
Colour rendition index	CRI>80
Lumen maintenance	L90/B10 ≤50000h
LED failure rate	0.1% ≤50000h
Dimming range	0.1%-100%
Dimming method	CCR
LMF	E
Energy efficiency class	EEL A++
Standby power per control gear	0.4W
Luminaires per circuit breaker B16	200
Temperature on the light aperture	35°C

For your regional contact in the ERCO Sales network click here www.ercos.com/contact

Technical Region: 220V-240V/50Hz
We reserve the right to make technical and design changes.
Edition: 06.12.2016
Current version under www.ercos.com/33924.000

Planning data

Cleaning (a)	1				2				3			
	P	C	N	D	P	C	N	D	P	C	N	D
LMF	0.96	0.94	0.90	0.86	0.93	0.91	0.86	0.81	0.92	0.90	0.84	0.79
RSMF	0.97	0.95	0.91	0.86	0.97	0.94	0.90	0.86	0.97	0.94	0.90	0.86

Hours of operation (h)	1000	5000	10000	20000	30000	40000	50000
LLMF	1.00	0.99	0.98	0.96	0.94	0.92	0.90
LSF	1	1	1	1	1	1	1

- MF LMFxRSMFxLLMFxLSF
- MF Maintenance Factor
- LMF Luminaire Maintenance Factor
- RSMF Room Surface Maintenance Factor
- LLMF Lamp Lumens Maintenance Factor
- LSF Lamp Survival Factor
- P Room pure
- C Room clean
- N Room normal
- D Room dirty

Technical data based on international standards and directives

- IEC 60598 Luminaires – Parts 1+2: General requirements, particular requirements and tests
- IEC 62031 LED modules for general lighting – Safety specifications
- IEC 62471 Photobiological safety of lamps and lamp systems
- EN 13032-4 Light and lighting – Measurement and presentation of photometric data of lamps and luminaires
- CIE 13 Method of measuring and specifying colour rendering of light sources

Accessories



34974.000
Distribution box, IP68
With four cable entries, 7-25mm.
Polymer.
ø 102mm, L 305mm.
Weight 0.47kg
CE IP 68 3m

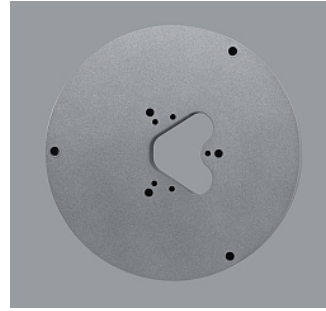

33982.000
Mounting plate
Corrosion-resistant cast aluminium,
No-Rinse surface treatment. Graphit m,
double powder-coated.
Weight 1.70kg



33974.000
Ground socket
Metal, hot-dip galvanised.
Cable entry.
Weight 2.30kg

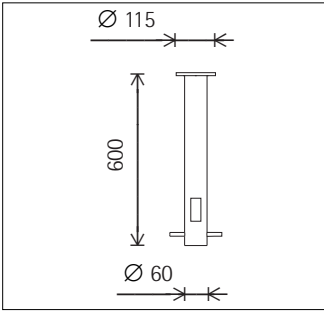
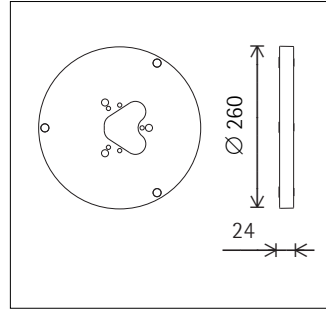

33981.000
Concrete anchor
Mounting plate with threaded bar and
fixing nuts M10. Individual parts to be
assembled on-site.
Weight 0.76kg

